

9mm common drawing

Model No. R0921G-xA1- taper value

接线图
Circuit explanation

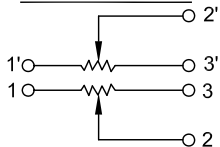

安装孔位置图
P.C.B. mounting hole detail

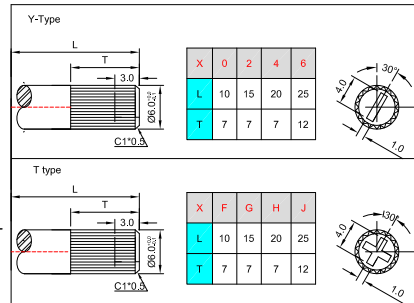
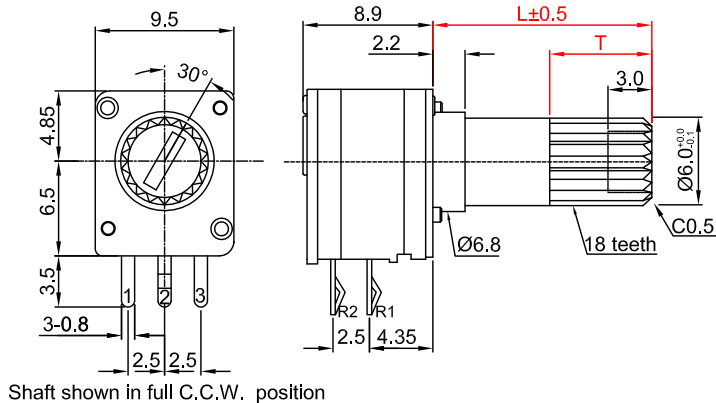
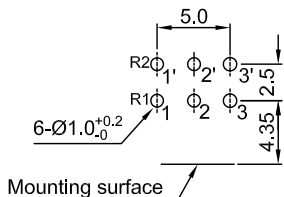

YU WAH (D G) CO.,LTD

9 mm Rotary Potentiometers with SW series Specifications

1. 電氣性能 (Electrical Characteristics)		
1.1	全阻抗值 (Total Resistance)	1K Ω ~ 2M Ω
1.2	全阻抗值允許偏差 (Total Resistance Tolerance)	$\pm 20\%$ (More than 1 M Ω $\pm 30\%$)
1.3	電阻隨溫度變化特性 Resistance of temperature change character	20 $^{\circ}$ C-75 $^{\circ}$ C: $\Delta R/R \leq \pm 5\%$, -25 $^{\circ}$ C-20 $^{\circ}$ C: $\Delta R/R \leq \pm 4.5\%$
1.4	阻值變化特性 (Resistance Taper)	A, B, C, W
1.5	零位阻值 (Residual Resistance)	R $>$ 250K Ω / 0.1 % max. of total Value 250K Ω $>$ R $>$ 10K Ω / 20 Ω max. 10K Ω $>$ R / 10 Ω max.
1.6	額定功率 (Rated Power)	Linear Taper B: 0.05W Other Taper:0.025W
1.7	最高使用電壓 (Max.Operating Voltage)	50V AC
1.8	動雜音 (Rotational Noise)	Less Than 100mV
1.9	絕緣阻抗 (Insulation Resistance)	More than 100M Ω at DC 250V
1.10	耐電壓 (Withstand Voltage)	For 1 minute at: AC 250V
1.11	開關額定功率(Switch Rated Power)	-----
1.12	同步誤差 (Gang Error)	-----
2. 機械性能 (Mechanical Characteristics)		
2.1	全回轉角度 (Rotation Angle)	300 $^{\circ}$ \pm 10 $^{\circ}$
2.2	旋轉力矩 (Rotation Torque)	20~200gf.cm
2.3	軸的拉、押強度 (Pull-Push Strength)	3 Kgf.cm
2.4	轉動止檔強度 (Rotational Stop-End Torque)	2.5 kgf.cm Min
2.5	開關角度(Switch Working Angel)	-----
2.6	開關力矩(Switch Working Torque)	-----
2.7	旋轉定位數目 (Number of Detents(click))	detent: 0, & 1 centre click
2.8	焊錫耐熱性 (Resistance To Soldering Heat)	<u>260</u> \pm 5 $^{\circ}$ C and less than <u>3</u> seconds
3. 耐久性能 (Durability)		
3.1	回轉壽命 (Rotation Life)	10,000 Cycles min.
3.2	工作溫度 (Operating temperature)	-10 $^{\circ}$ C ~ +70 $^{\circ}$ C
4.1	外形尺寸圖/曲線特性圖 (Shape size drawing/curve characteristic drawing)	見附頁 Please refer the drawing